



# WATERTIGHT TANK ACCESS CHAMBERS



**SM5542**  
**SM5542L**



- ◆ Spacious octagonal base for structural strength when back filled, comfortable access and eight pipe entry orientations
- ◆ Large flat panels for installation of “Easy Fit” pipe entry fittings
- ◆ Corrugated, height-trimmable riser, available in two lengths
- ◆ Chamber meets the confined workspace safety requirements
- ◆ Chamber is closed and sealed with a lid
- ◆ Made of PE material that is easy and safe to work with
- ◆ All gaskets in Nitrile rubber
- ◆ Compatible with high blend Ethanol fuels (E85) and bio-diesel
- ◆ Vacuum testable with Magnum VI system



# TANK SUMP - STREET COVER KIT SM5542FR-SLC4200

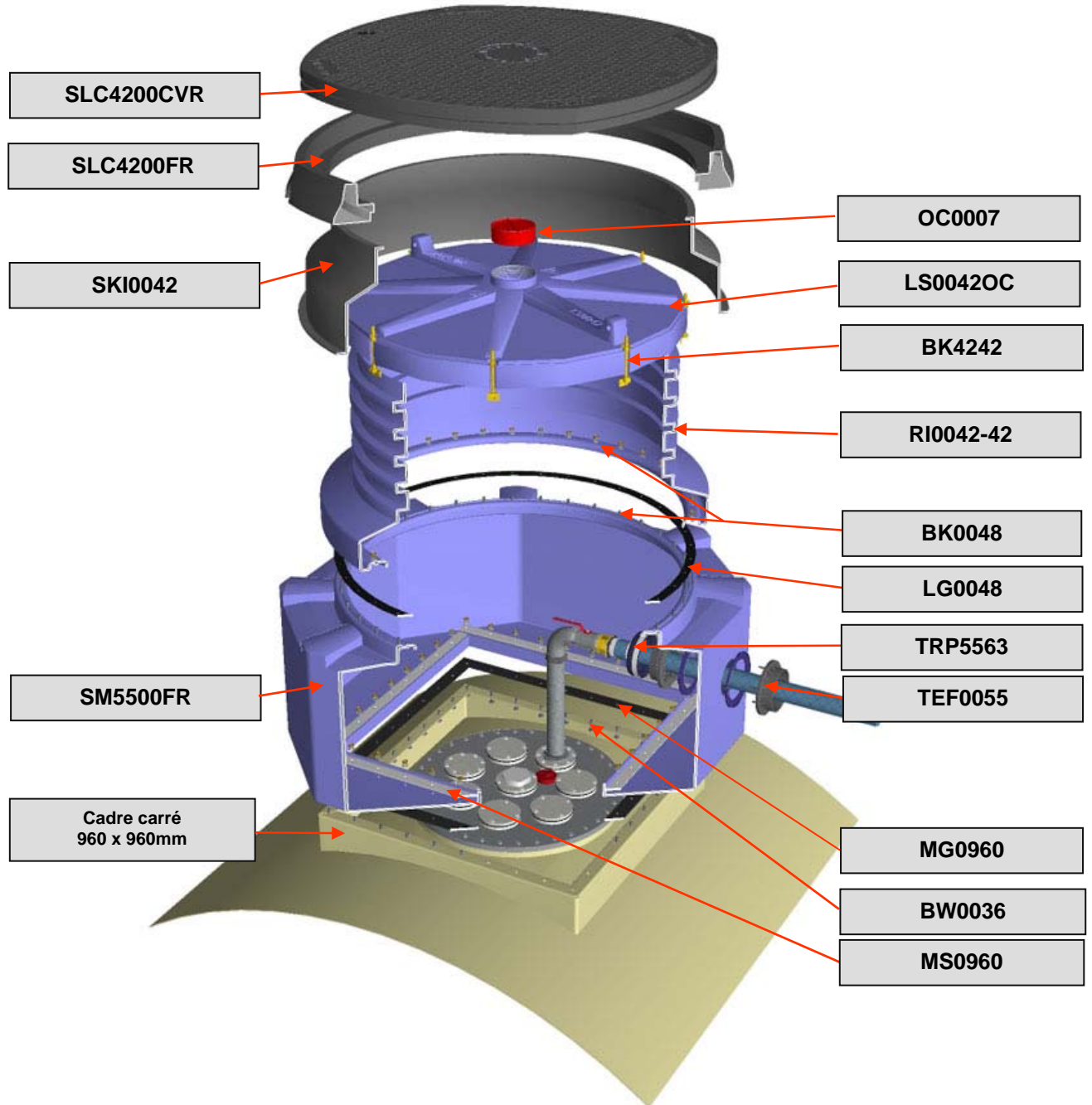

The SM5500 sump base is available with plain bottom for cut out on site to match the provided tankframe.



# TANK SUMP - STREET COVER KIT SM5542SC-SLC4200

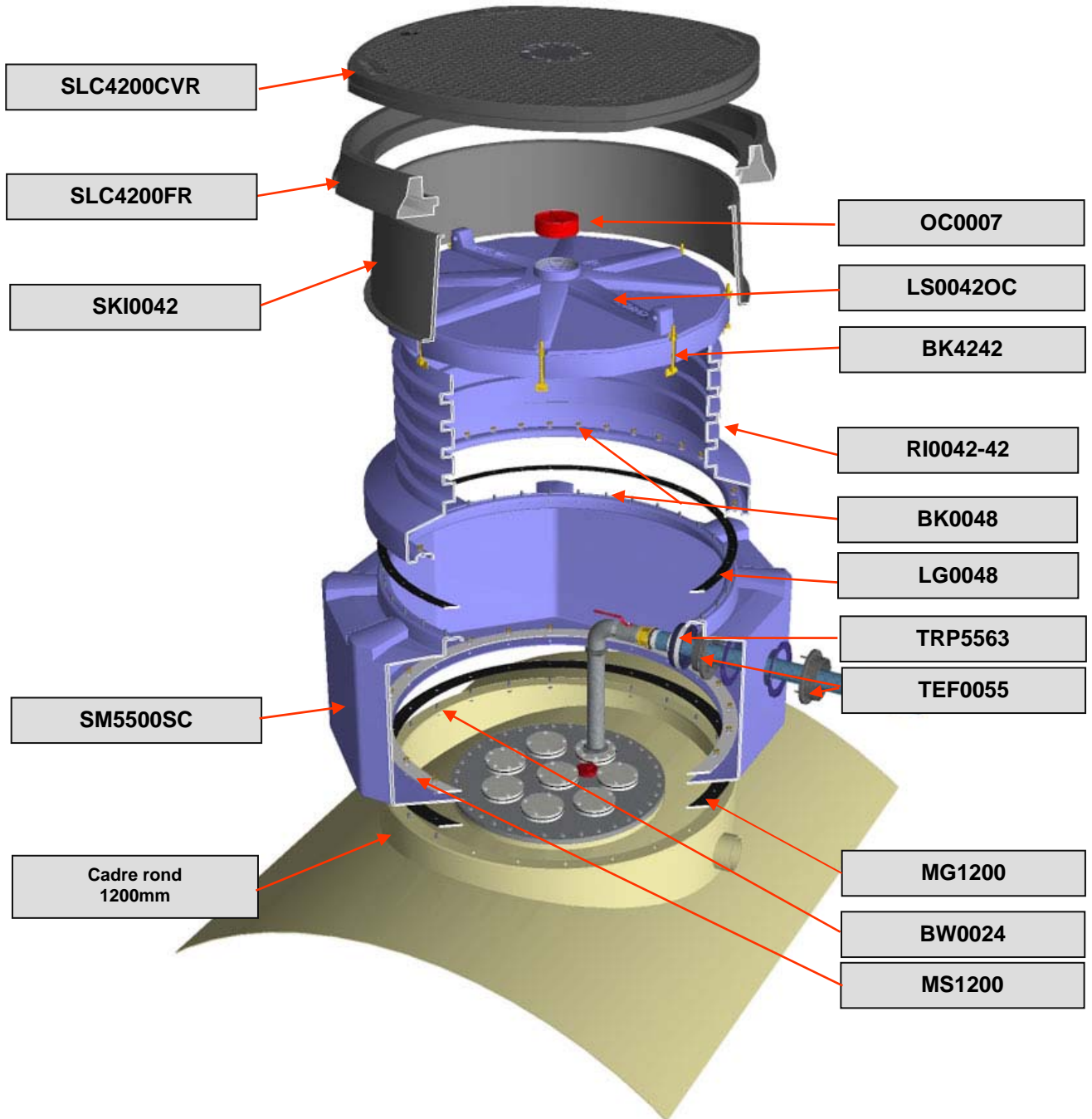

The SM5500 sump base is available with plain bottom for cut out on site to match the provided tankframe.



# TANK SUMP - STREET COVER KIT SM5542FRL-SLC4200DC

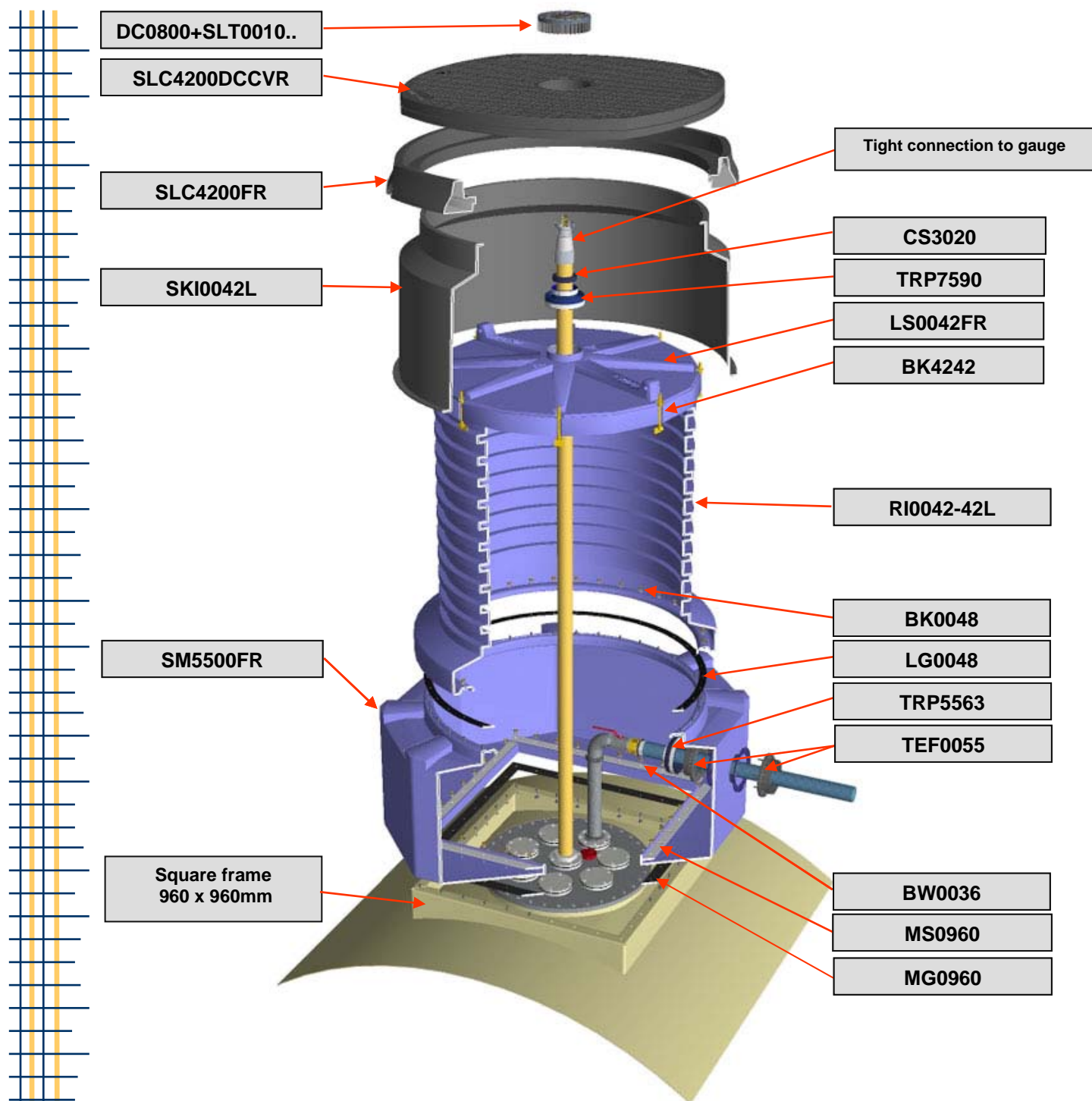

The SM5500 sump base is available with plain bottom for cut out on site to match the provided tankframe.



# WATER TIGHT TANK ACCESS CHAMBERS

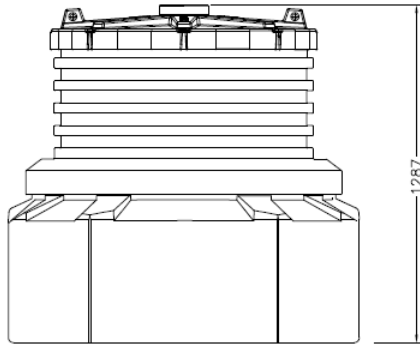

**SM5542**

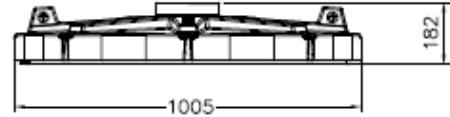

**LS0042OC**

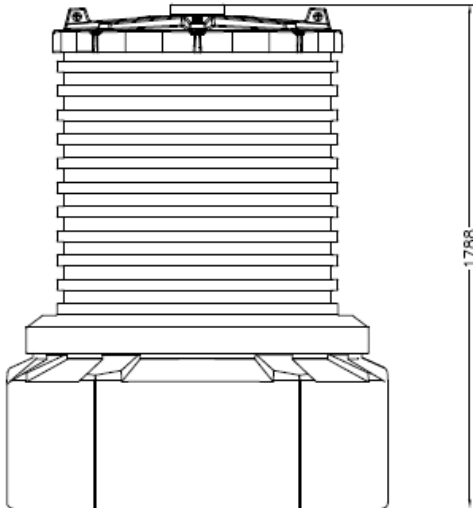
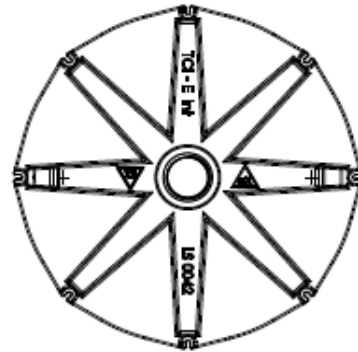

**SM5542L**

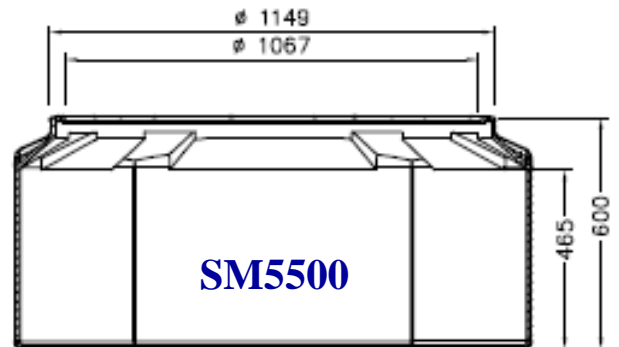

**SM5500**

Installation drawings available on request





# WATERTIGHT TANK ACCESS CHAMBERS

Product Code	Description
DC0800 SLT0010xx	<b>Central Dip cap for street covers</b> <b>Set of two colour plates for central dipcap</b> xx = YE : Yellow      OR : Orange      BL : Black GR : Green      PU : Purple      WH : White MA : Auburn      RD : Red      BE : Blue
SLC4200FR SLC4200CVR SLC4200DCCVR SKI0042 SKI0042L	<b>Composite Street Cover, EN124 Class C (25ton)</b> Composite frame for 42" cover Composite cover 42", without central dipping opening Composite cover 42", with central dipping opening Skirt for FR4200 frame; 300mm deep Skirt for FR4200 frame; 600mm deep
SM5500 SM5500FR SM5500SC LG0048 BK0048 RI0042-42 RI0042-42L LS00420C LS0042FR BK4242	<b>Tank Sump</b> Octagonal Base, 55" - 1,35m, plain bottom Octagonal Base, 55" - 1,35m, square bottom cut for upstand frame 960 x 960mm Octagonal Base, 55" - 1,35m, round bottom cut for upstand frame 1.200mm Nitrile Gasket, base to riser Bolt kit, base to riser Round Corrugated Riser, O.D. 42" - 1m, height 23" - 0,59m Round Corrugated Riser, O.D. 42" - 1m, height 43" - 1,10m Lid O.D. 42" - 1 m with central observation cap OC0007 Lid O.D. 42" - 1 m with central free passage for manual dip tube Lid to riser mounting kit
MG0960 MS0960 BW0036	<b>Base to Tank installation kit, for square upstand frame 960x 960mm</b> Square Nitrile Gasket, 960 x 960mm Compression strips (4) for 960 x 960mm frame Bolt kit, Base to Tank Upstand Frame
MG1200 MS1200 BW0024	<b>Base to Tank installation kit, for round upstand frame 1.200mm</b> Round Gasket, 1.200mm Compression strip for 1.200mm round frame Bolt kit, Base to Tank Upstand Frame

For the pipe entry fittings consult the "EASY FIT" brochure.

